

SEMITRANS® 3

Trench IGBT Modules

SKM 200GB126D

SKM 200GAL126D

Features

- Trench = Trenchgate technology
- $V_{CE(sat)}$ with positive temperature coefficient
- High short circuit capability, self limiting to $6 \times I_C$

Typical Applications

- Electronic welders
- AC inverter drives
- UPS

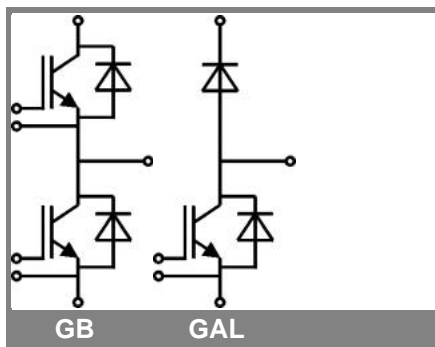

Absolute Maximum Ratings		$T_{case} = 25^\circ\text{C}$, unless otherwise specified		
Symbol	Conditions	Values		Units
IGBT				
V_{CES}	$T_j = 25^\circ\text{C}$	1200		V
I_C	$T_j = 150^\circ\text{C}$	$T_c = 25^\circ\text{C}$	260	A
		$T_c = 80^\circ\text{C}$	190	A
I_{CRM}	$I_{CRM} = 2 \times I_{Cnom}$	300		A
V_{GES}		± 20		V
t_{psc}	$V_{CC} = 600\text{ V}; V_{GE} \leq 20\text{ V}; T_j = 125^\circ\text{C}$ $V_{CES} < 1200\text{ V}$	10		μs
Inverse Diode				
I_F	$T_j = 150^\circ\text{C}$	$T_c = 25^\circ\text{C}$	200	A
		$T_c = 80^\circ\text{C}$	140	A
I_{FRM}	$I_{FRM} = 2 \times I_{Fnom}$	300		A
I_{FSM}	$t_p = 10\text{ ms}; \sin.$	$T_j = 150^\circ\text{C}$	1100	A
Freewheeling Diode				
I_F	$T_j = 150^\circ\text{C}$	$T_{case} = 25^\circ\text{C}$	200	A
		$T_{case} = 80^\circ\text{C}$	140	A
I_{FRM}	$I_{FRM} = 2 \times I_{Fnom}$	300		A
I_{FSM}	$t_p = 10\text{ ms}; \sin.$	$T_j = 150^\circ\text{C}$	1100	A
Module				
$I_{t(RMS)}$		500		A
T_{vj}		- 40 ... + 150		$^\circ\text{C}$
T_{stg}		- 40 ... + 125		$^\circ\text{C}$
V_{isol}	AC, 1 min.	4000		V

Characteristics		$T_{case} = 25^\circ\text{C}$, unless otherwise specified			
Symbol	Conditions	min.	typ.	max.	Units
IGBT					
$V_{GE(th)}$	$V_{GE} = V_{CE}, I_C = 6\text{ mA}$	5	5,8	6,5	V
I_{CES}	$V_{GE} = 0\text{ V}, V_{CE} = V_{CES}$	$T_j = 25^\circ\text{C}$	0,1		mA
		$T_j = 125^\circ\text{C}$	0,3		mA
V_{CE0}		$T_j = 25^\circ\text{C}$	1		V
		$T_j = 125^\circ\text{C}$	0,9		V
r_{CE}	$V_{GE} = 15\text{ V}$	$T_j = 25^\circ\text{C}$	4,7		$\text{m}\Omega$
		$T_j = 125^\circ\text{C}$	7,3		$\text{m}\Omega$
$V_{CE(sat)}$	$I_{Cnom} = 150\text{ A}, V_{GE} = 15\text{ V}$	$T_j = 25^\circ\text{C}_{chiplev.}$	1,7		V
		$T_j = 125^\circ\text{C}_{chiplev.}$	2		V
C_{ies}	$V_{CE} = 25, V_{GE} = 0\text{ V}$	$f = 1\text{ MHz}$	10,8		nF
C_{oes}			0,9		nF
C_{res}			0,9		nF
Q_G	$V_{GE} = -8\text{ V} - +20\text{ V}$	1530		nC	
R_{Gint}	$T_j = 25^\circ\text{C}$	5		Ω	
$t_{d(on)}$	$R_{Gon} = 1,5\ \Omega$	$V_{CC} = 600\text{ V}$ $I_{Cnom} = 150\text{ A}$	260		ns
t_r			40		ns
E_{on}	$R_{Goff} = 1,5\ \Omega$	$T_j = 125^\circ\text{C}$ $V_{GE} = \pm 15\text{ V}$	18		mJ
$t_{d(off)}$			540		ns
t_f			110		ns
E_{off}	per IGBT		0,13		mJ
$R_{th(j-c)}$			K/W		

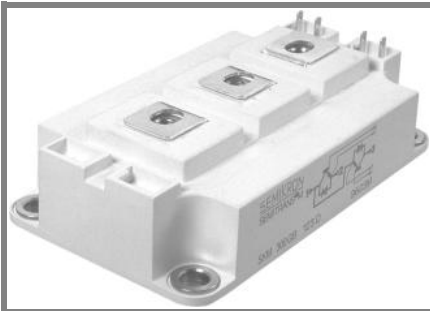

SEMITRANS® 3

Trench IGBT Modules

SKM 200GB126D

SKM 200GAL126D

Features

- Trench = Trenchgate technology
- $V_{CE(sat)}$ with positive temperature coefficient
- High short circuit capability, self limiting to $6 \times I_C$

Typical Applications

- Electronic welders
- AC inverter drives
- UPS

Characteristics					
Symbol	Conditions	min.	typ.	max.	Units
Inverse diode					
$V_F = V_{EC}$	$I_{Fnom} = 150 \text{ A}; V_{GE} = 0 \text{ V}$	$T_j = 25 \text{ }^\circ\text{C}_{chiplev.}$	1,6	1,8	V
		$T_j = 125 \text{ }^\circ\text{C}_{chiplev.}$	1,6	1,8	V
V_{F0}		$T_j = 25 \text{ }^\circ\text{C}$	1	1,1	V
		$T_j = 125 \text{ }^\circ\text{C}$	0,8	0,9	V
r_F		$T_j = 25 \text{ }^\circ\text{C}$	4	4,7	mΩ
		$T_j = 125 \text{ }^\circ\text{C}$	5,3	6	mΩ
I_{RRM}	$I_{Fnom} = 150 \text{ A}$	$T_j = 125 \text{ }^\circ\text{C}$	240		A
Q_{rr}	$di/dt = 5000 \text{ A}/\mu\text{s}$		42		μC
E_{rr}	$V_{GE} = -15 \text{ V}; V_{CC} = 600 \text{ V}$				mJ
$R_{th(j-c)D}$	per diode			0,3	K/W
FWD					
$V_F = V_{EC}$	$I_{Fnom} = 150 \text{ A}; V_{GE} = 0 \text{ V}$	$T_j = 25 \text{ }^\circ\text{C}_{chiplev.}$	1,6	1,8	V
		$T_j = 125 \text{ }^\circ\text{C}_{chiplev.}$	1,6	1,8	V
V_{F0}		$T_j = 25 \text{ }^\circ\text{C}$	1	1,1	V
		$T_j = 125 \text{ }^\circ\text{C}$	0,8	0,9	V
r_F		$T_j = 25 \text{ }^\circ\text{C}$	4	4,7	V
		$T_j = 125 \text{ }^\circ\text{C}$	5,3	6	V
I_{RRM}	$I_{Fnom} = 150 \text{ A}$	$T_j = 125 \text{ }^\circ\text{C}$	240		A
Q_{rr}	$di/dt = 5000 \text{ A}/\mu\text{s}$		42		μC
E_{rr}	$V_{GE} = -15 \text{ V}; V_{CC} = 600 \text{ V}$				mJ
$R_{th(j-c)FD}$	per diode			0,3	K/W
Module					
L_{CE}			15	20	nH
$R_{CC'+EE'}$	res., terminal-chip	$T_{case} = 25 \text{ }^\circ\text{C}$	0,35		mΩ
		$T_{case} = 125 \text{ }^\circ\text{C}$	0,5		mΩ
$R_{th(c-s)}$	per module			0,038	K/W
M_s	to heat sink M6		3	5	Nm
M_t	to terminals M5		2,5	5	Nm
w				325	g

This is an electrostatic discharge sensitive device (ESDS), international standard IEC 60747-1, Chapter IX.

This technical information specifies semiconductor devices but promises no characteristics. No warranty or guarantee expressed or implied is made regarding delivery, performance or suitability.

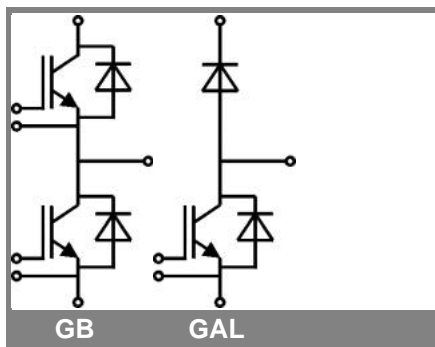

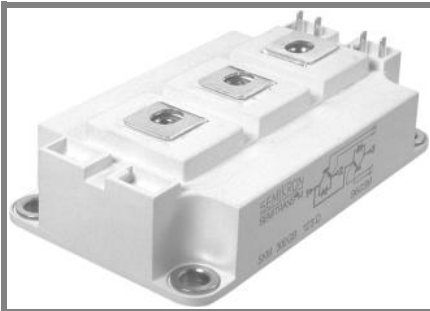

SEMITRANS® 3

Trench IGBT Modules

SKM 200GB126D

SKM 200GAL126D

Features

- Trench = Trenchgate technology
- $V_{CE(sat)}$ with positive temperature coefficient
- High short circuit capability, self limiting to $6 \times I_C$

Typical Applications

- Electronic welders
- AC inverter drives
- UPS

Z_{th}		Conditions	Values	Units
$Z_{th(j-c)I}$				
$R_{\theta j-c}$		$i = 1$	95	mk/W
$R_{\theta j-c}$		$i = 2$	27	mk/W
$R_{\theta j-c}$		$i = 3$	6,7	mk/W
$R_{\theta j-c}$		$i = 4$	1,3	mk/W
$\tau_{\theta j-c}$		$i = 1$	0,0744	s
$\tau_{\theta j-c}$		$i = 2$	0,0087	s
$\tau_{\theta j-c}$		$i = 3$	0,002	s
$\tau_{\theta j-c}$		$i = 4$	0,0001	s
$Z_{th(j-c)D}$				
$R_{\theta j-c}$		$i = 1$	200	mk/W
$R_{\theta j-c}$		$i = 2$	80	mk/W
$R_{\theta j-c}$		$i = 3$	17	mk/W
$R_{\theta j-c}$		$i = 4$	3	mk/W
$\tau_{\theta j-c}$		$i = 1$	0,0536	s
$\tau_{\theta j-c}$		$i = 2$	0,0056	s
$\tau_{\theta j-c}$		$i = 3$	0,09	s
$\tau_{\theta j-c}$		$i = 4$	0,0002	s

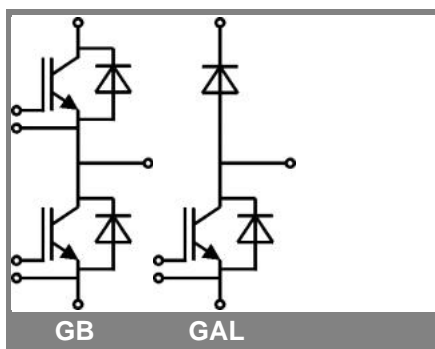

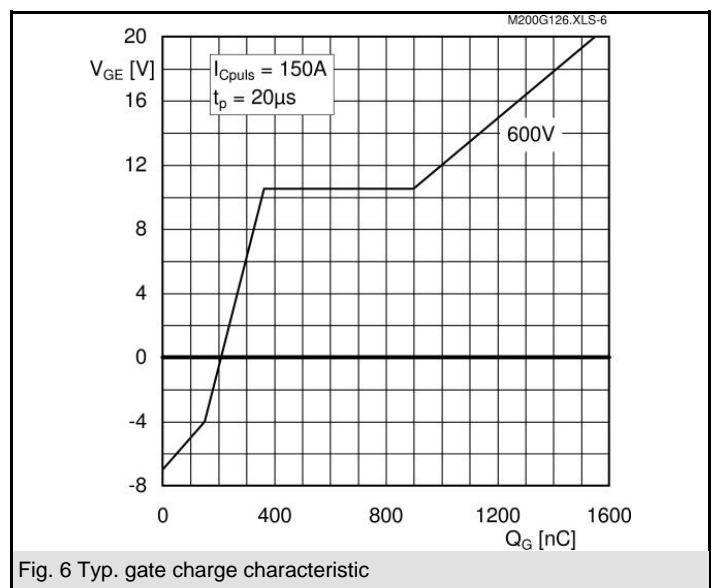
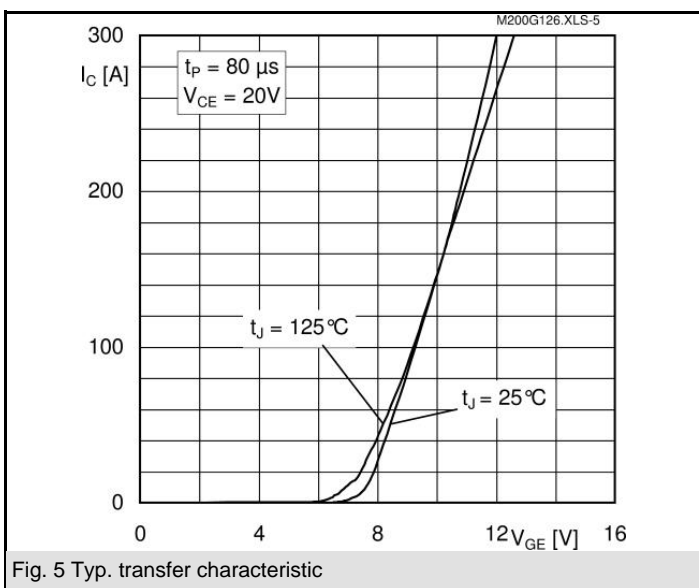
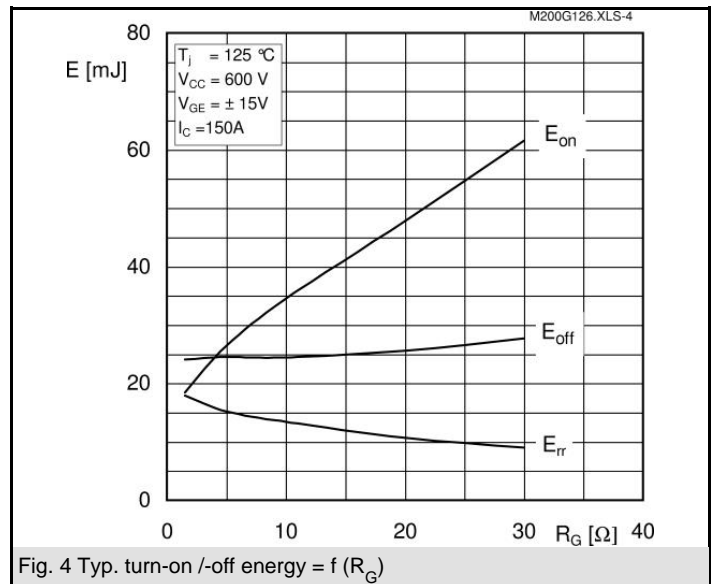
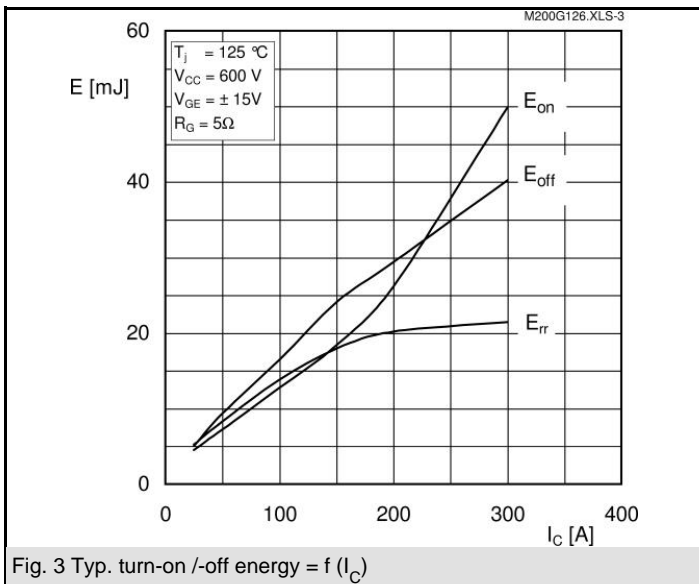
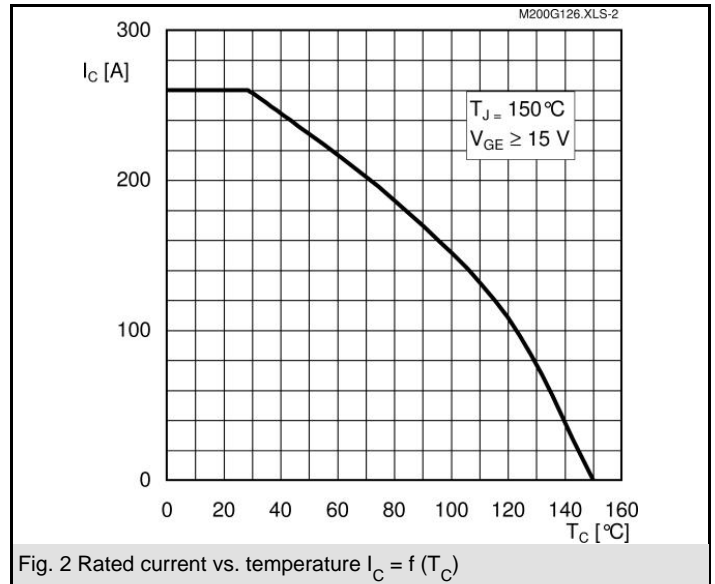
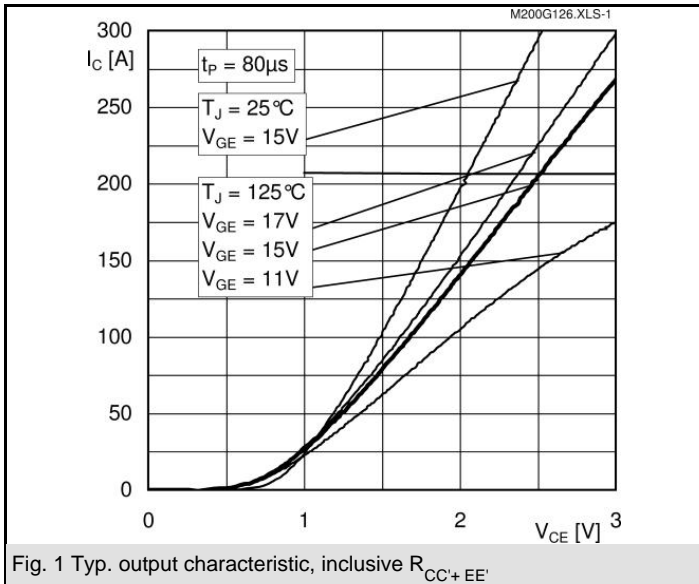

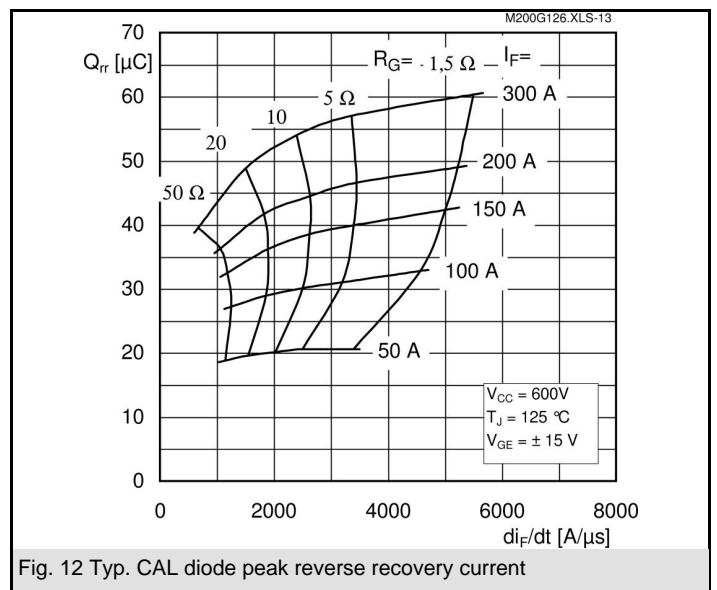
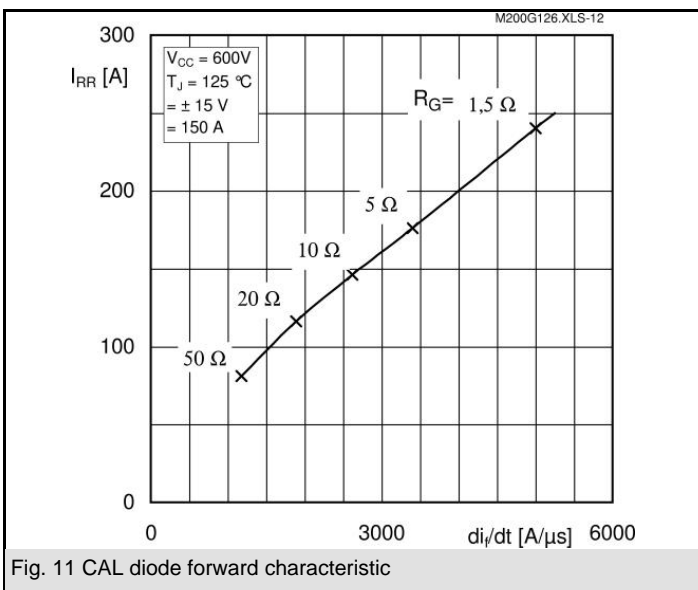
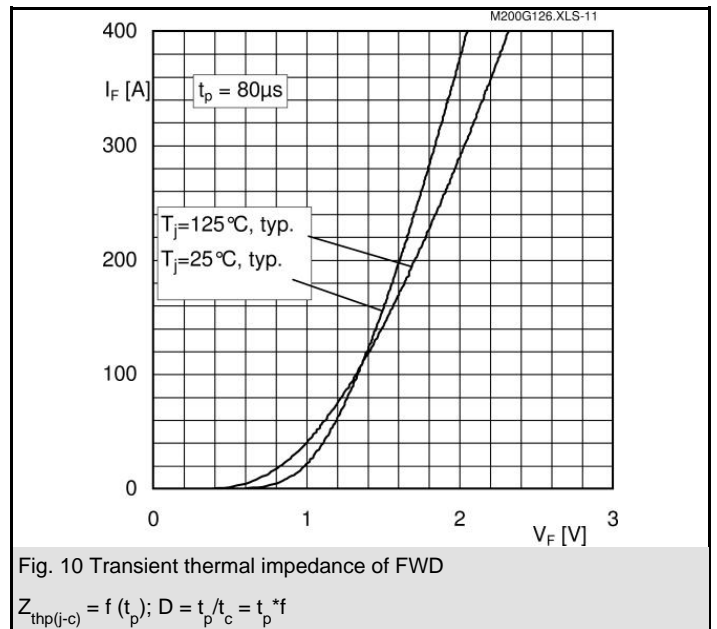
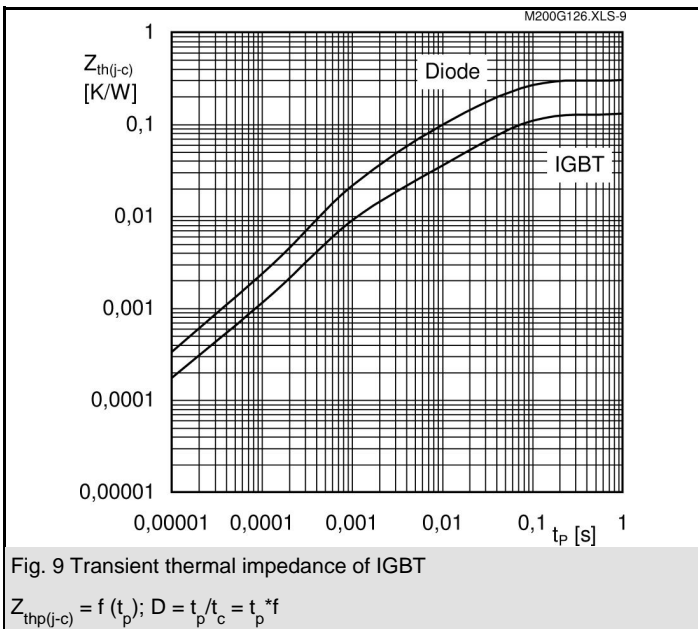
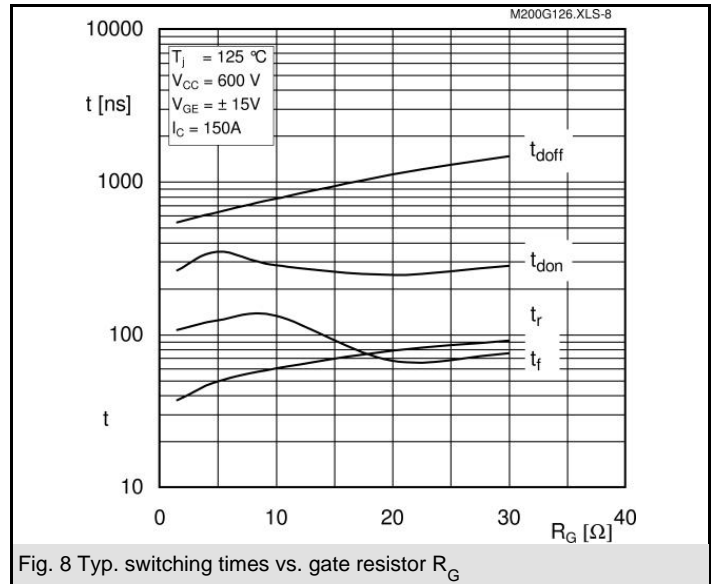
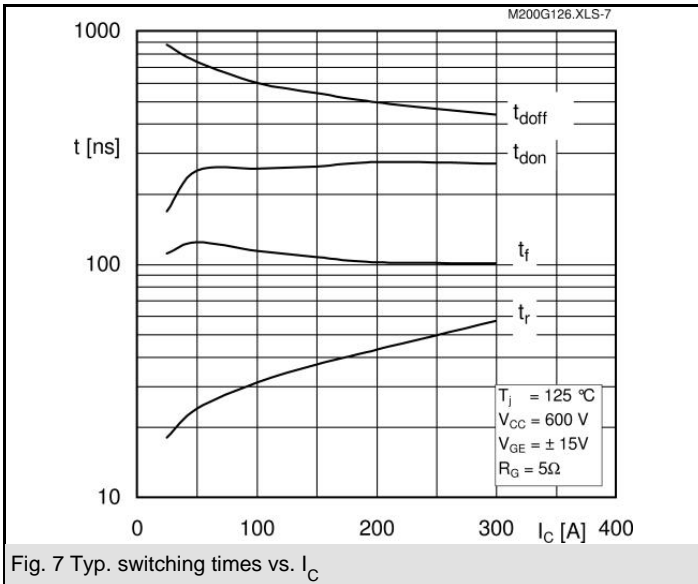

SKM 200GB126D ...

UL Recognized
File no. E 63 532

Dimensions in mm

CASED56

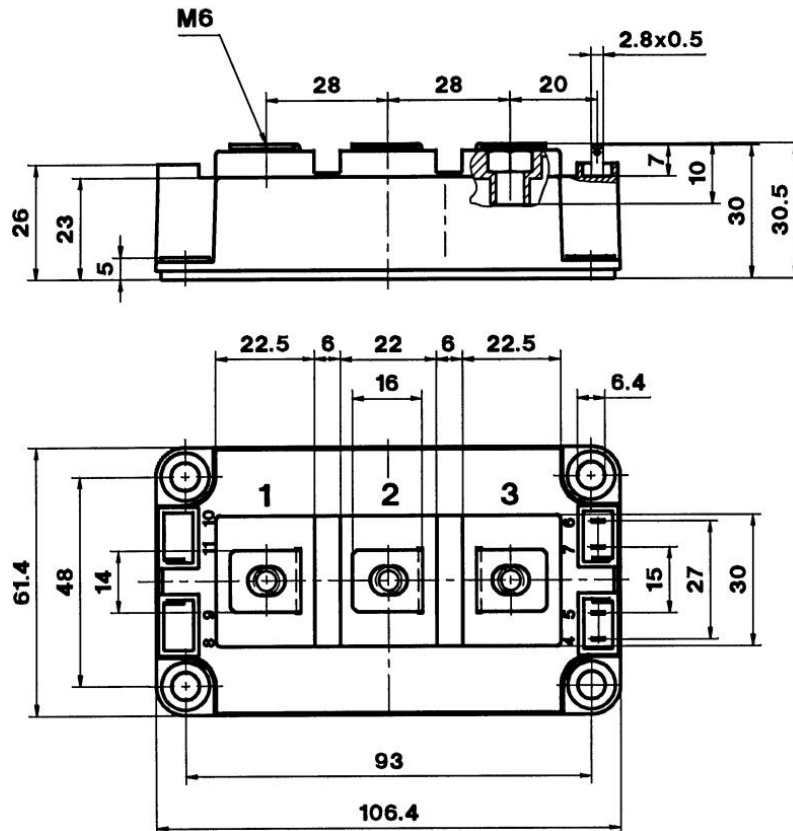

Case D 56

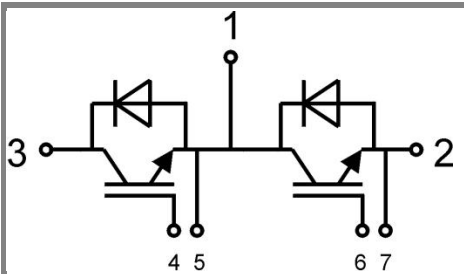

Case D56

GB

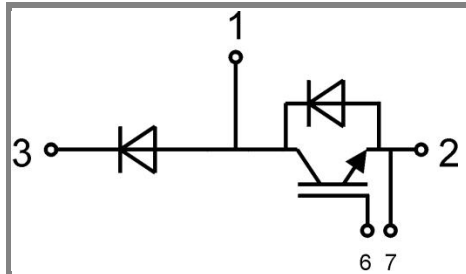

Case D57

GAL